

Lattices and Manifolds of Classes of Flat Riemannian Tori

RAFAEL RAMÍREZ-UCLÉS

*Departamento de Geometría y Topología, Facultad de Ciencias,
Universidad de Granada, 18071-Granada, Spain
rramirez@ugr.es*

Presented by Antonio M. Cegarra

Received February 17, 2010

Abstract: The topological and differentiable structures of some natural quotient spaces constructed from flat Riemannian tori are studied by means of a cut-and-paste procedure (concretely, $H \backslash (Gl^+(2, \mathbb{R})/Sl(2, \mathbb{Z}))$, where $H = O^+(2, \mathbb{R}), CO^+(2, \mathbb{R}), O(2, \mathbb{R}), CO(2, \mathbb{R})$). In the orientation preserving cases, the quotients can be regarded as manifolds with singular points corresponding to lattices in the square and hexagonal crystal systems. In the non-orientation preserving ones, the natural structure is a smooth manifold with piecewise smooth boundary, where the interior points correspond to oblique lattices, the regular points of the boundary to rectangular and centered rectangular lattices and the edge of the boundary to square and hexagonal ones.

Key words: Flat and conformally flat tori, bidimensional crystallographic system, moduli space, lattice, orbifold.

AMS Subject Class. (2000): 53C15, 51N30, 32G15.

1. INTRODUCTION

It is well-known that any flat Riemannian torus can be regarded as a planar lattice, i.e., a quotient \mathbb{R}^2/G where G is a group of translations generated by two independent elements. On one hand, such lattices are well-known since long time ago -before Bieberbach's solution to Hilbert's 18th problem-, and they are classified in classical crystallographic systems. On the other, from a geometrical viewpoint, it is natural to identify some of the tori by several distinct criteria. Concretely, one can consider the space of all the flat Riemannian tori up to (oriented or not) isometries or conformal transformations. These spaces are topological quotients with an obvious geometrical interpretation and interest. For example, it is known that any Riemannian torus is globally conformal to a flat one, and then, the set of all the complex structures (as Riemann surfaces) on the torus are in natural bijective correspondence with the quotient set of all the flat Riemannian tori up to oriented conformal transformations [6, Section IV.7]. Nevertheless, even though it is not difficult to

compute their topological structure, the differentiable structure of these quotients become subtler, because this structure is not transferred to the quotient in a standard way. Our aim in the present article is to study carefully both, their topological and differentiable structures, identifying the crystallographic systems where the structures become singular.

Recall that a topological manifold may contain different differentiable structures (even though necessarily diffeomorphic in dimensions 2, 3) and, depending on the problem under study, one may prefer one of them, or regard the manifold as non-differentiable. For example, the cone $C = \{(x, y, z) \in \mathbb{R}^3 : z = \sqrt{(x^2 + y^2)}/3, 0 \leq x, y < 1\}$, with its natural topology, is a topological 2-manifold, and it admits a differentiable structure generated by the global chart $(x, y, z) \rightarrow (x, y)$. Nevertheless, when C is regarded as a topological surface of \mathbb{R}^3 , one assumes that the differentiable structure should make the inclusion $i : C \rightarrow \mathbb{R}^3$ a differentiable embedding and, then, C is regarded as non-differentiable at the vertex. One can also consider C as being essentially an orbifold. Let D be the open disk of radius 1 in \mathbb{R}^2 , and consider the action of the group $G = \mathbb{Z}_2$ on D through rotations of 0 or π radians. Now, D/\mathbb{Z}_2 is naturally an orbifold identifiable to C , being the (class of the) origin its unique singular point. Recall that an orbifold structure allows to consider differentiability even at the singular points. Finally, this orbifold can be also viewed as a quotient space obtained by cutting and gluing, namely, identifying in $\{(x, y) \in D : x \geq 0\}$ each point $(0, y)$ with $(0, -y)$ —nevertheless, all the glued points could be also regarded as singular if the quotient space were identified with a different topological cone C' in \mathbb{R}^3 , which makes an angle ($\neq \pi$) along both sides of a generatrix.

The set of all the planar lattices is the quotient manifold $Gl^+(2, \mathbb{R})/Sl(2, \mathbb{Z})$. As $Sl(2, \mathbb{Z})$ is a closed subgroup, the quotient admits a natural structure of smooth 4-manifold. In Section 2, we reconstruct this manifold by introducing a chart in an open dense subset; this allows to consider $Gl^+(2, \mathbb{R})/Sl(2, \mathbb{Z})$ as a subset of \mathbb{R}^4 with some points identified (Section 2.3). Recall that, as the structure of the quotient is known to be smooth a priori, all these identifications must be regarded also as smooth.

In Section 3, we wonder when two such lattices represent isometric oriented flat Riemannian tori (resp. conformal oriented flat Riemannian tori; isometric flat Riemannian tori; conformal flat Riemannian tori). The space of all these tori is naturally a further quotient $G_H = H \backslash (Gl^+(2, \mathbb{R})/Sl(2, \mathbb{Z}))$ where $H = O^+(2, \mathbb{R})$ (resp, $CO^+(2, \mathbb{R})$; $O(2, \mathbb{R})$; $CO(2, \mathbb{R})$). Computations or applications of the point set or topological structures of these quotients can

be found, for example, in [2], [6], [7], [8], [14]. Quotients G_H are particular cases of *orbispaces*, in the sense of [3]. Under our approach, the topological structure of G_H is computed by introducing new explicit identifications; then, one can make natural choices to fix if the identified points either preserve the differentiable structure or are singular. In fact, G_H becomes either an orbifold with two connected parts of singular points (in the orientation-preserving cases: $H = O^+(2, \mathbb{R})$, $CO^+(2, \mathbb{R})$) or a smooth manifold with a (connected) piecewise smooth boundary (cases $H = O(2, \mathbb{R})$, $CO(2, \mathbb{R})$). Even more, the explicit identifications allows to control the crystal systems of the singular, regular or boundary points. Our results can be summarized then as follows (by *line* and *plane* we mean a smooth manifold diffeomorphic to \mathbb{R} and \mathbb{R}^2 , respectively):

THEOREM 1.1. *For each one of the groups H in the cases below, the quotient space $G_H = H \backslash (Gl(2, \mathbb{R})^+ / Sl(2, Z))$ is a topological n -manifold ($n = 2, 3$), eventually with boundary, with the following properties:*

- *Case $H = O^+(2, \mathbb{R})$ (set of all the flat Riemannian tori up to oriented isometries). G_H is homeomorphic to \mathbb{R}^3 and admits a natural structure of smooth manifold with singular points distributed in two lines: one corresponds with the lattices in the square crystal system, and the other with lattices in the hexagonal one.*
- *Case $H = CO^+(2, \mathbb{R})$ (set of all the flat Riemannian tori up to oriented conformal diffeomorphisms –or, equivalently, set of all the Riemann surface structures on a torus). G_H is homeomorphic to \mathbb{R}^2 and admits a natural structure of smooth manifold with two singular points: one is the class of all the lattices in the square crystal system, and the other the class of all the lattices in the hexagonal one (Figure 8).*
- *Case $H = O(2, \mathbb{R})$ (set of all the flat Riemannian tori up to isometries). G_H is homeomorphic to a closed semi-space $\mathbb{R}_0 \times \mathbb{R}^2$ of \mathbb{R}^3 , where the interior points are all the classes of lattices in the oblique crystal system. It also admits a natural structure of smooth 3-manifold with piecewise smooth boundary ∂G_H such that ∂G_H contains:*
 - *Two disjoint singular lines (2-edge): one with classes of lattices in the square crystal system, and the other with classes in the hexagonal one.*

- Three disjoint regular planes (1-edge) separated by the singular lines: one of them contain the classes of lattices in the rectangular crystal system, and the other two classes in the centered rectangular one.
- Case $H = CO(2, \mathbb{R})$ (set of all the flat Riemannian tori up to conformal transformations): G_H is homeomorphic to a closed semi-plane $\mathbb{R}_0^+ \times \mathbb{R}$, where the interior points are all the classes of lattices in the oblique crystal system. It also admits a natural structure of smooth 2-manifold with piecewise smooth boundary ∂G_H such that ∂G_H contains:
 - Two singular points (2-edge): one is the class of the lattices in the square crystal system, and the other in the hexagonal one.
 - Three disjoint regular lines (1-edge) separated by the singular points: one of them contain the classes of lattices in the rectangular crystal system, and the other two classes in the centered rectangular one (Figure 9).

Finally, it is worth pointing out that analogous results for quotients of Lorentzian tori are much more complicated; in principle, one cannot expect so good structures for the quotients of flat or conformally related tori. For example, not all the Lorentzian tori are globally conformally flat [10]. The necessary and sufficient hypothesis for this property, is the existence of a timelike conformal vector field K , see [11]. And, even though some similarities occur for the tori which admit such a K , see [9], the particularities of this case suggest quotients by other types of structures, [15].

2. A CUT-AND-PASTE CONSTRUCTION FOR FLAT QUOTIENT TORI

Let $Gl(2, \mathbb{R})$ be the group of regular matrixes 2×2 . Given a basis $B = \{w_1, w_2\}$ of \mathbb{R}^2 , the lattice generated by B is the commutative subgroup $G(= G(w_1, w_2)) = \{mw_1 + nw_2 : m, n \in \mathbb{Z}\}$ of \mathbb{R}^2 ; this lattice is also generated by any two independent $v_1, v_2 \in G$ which span a parallelogram of minimum area. The associated torus is the quotient set $T_G = \mathbb{R}^2/G$, which inherits the canonical flat connection and orientation of \mathbb{R}^2 , as well as the usual Riemannian metric and its associated conformal structure. Such planar lattices are classically classified into five crystallographic groups [1, Ch. 1, pp. 52–53]: oblique (C_2), rectangular (D_2), centered rectangular (D_2^c), square (D_4) and hexagonal (D_6), see Figure 1.

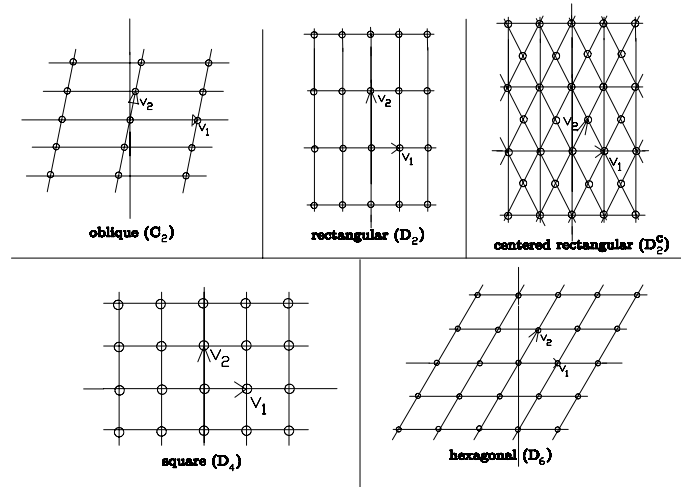

Figure 1: Bidimensional crystal system.

Given another basis $B' = \{w'_1, w'_2\}$ of \mathbb{R}^2 , the generated lattice and torus are equal if and only if the transition matrix A for the basis B, B' belongs to $Sl^\pm(2, \mathbb{Z})$ (i.e., the group of the 2×2 real matrixes with integer coefficients and determinant ± 1 , which admits the set $Sl(2, \mathbb{Z})$ of matrixes with determinant $+1$ as a normal subgroup). Thus, the set of all such tori is identifiable to the quotient $Gl(2, \mathbb{R})/Sl^\pm(2, \mathbb{Z}) = Gl^+(2, \mathbb{R})/Sl(2, \mathbb{Z})$. As $Sl(2, \mathbb{Z})$ is a closed 0-dimensional Lie subgroup of $Gl^+(2, \mathbb{R})$, the quotient inherits naturally a differentiable structure (a smooth one, i.e., C^∞) as an homogeneous 4-manifold.

2.1. CANONICAL REPRESENTATIVES FOR EACH LATTICE. Among the possible generators of the lattice G , a pair of representatives (v_1, v_2) of each lattice will be chosen in the following concrete way.

First, take v'_1 such that $\|v'_1\| = \min\{\|x\| : x \in G\}$, v'_1 lies in the closed upper semiplane and its angle θ'_1 with the x -axis is the smallest possible one. Then, choose v'_2 analogously, such that $\|v'_2\| = \min\{\|x\| : x \in G \setminus \{mv'_1 : m \in \mathbb{Z}\}\}$, v'_2 lies in the closed upper semiplane with smallest angle θ'_2 with the x -axis. Finally, let v_1 be the one of the v'_i 's with smaller angle with the x -axis and v_2 the one with bigger angle. Let θ be the angle between v_1 and v_2 : $\theta \in]0, \pi - \theta_1[$.

From now on, given v_1 and v_2 , we will put $r_i = \|v_i\|$, $i = 1, 2$, and θ_i will be the angle between v_i and the x -axis, $0 \leq \theta_1 < \theta_2 < \pi$. Vector v_i will be

identified with (r_i, θ_i) , thus, when there are no possibility of confusion, we will put $v_i \equiv (r_i, \theta_i)$.

LEMMA 2.1. *Given a lattice with canonical representatives v_1, v_2 :*

- (1) $\|v_1 + v_2\| \geq \|v_1\|$, $\|v_1 + v_2\| > \|v_2\|$;
- (2) $\|v_1 - v_2\| \geq \|v_i\|$, $i = 1, 2$, and if one of the equalities hold then $(v_2)_y > (v_1)_y$.

Proof. The equalities $\|v_1 \pm v_2\| \geq \|v_i\|$ follow from the choice of the v_i 's. Moreover, the angle between $v_1 \pm v_2$ and the x -axis is smaller than the one for v_2 and then:

- (1) The second equality for $v_1 + v_2$ cannot holds for the choice of v_2 .
- (2) If one of the equalities holds for $v_1 - v_2$, then $v_1 - v_2$ must lie in the open lower semi-plane, that is, $(v_2)_y > (v_1)_y$. ■

The following result shows that the proven inequalities for canonical representatives characterize them.

From now on, d will denote the usual distance on \mathbb{R}^2 , and $B(p, R)$ the open disc of center $p \in \mathbb{R}^2$ and radius $R > 0$.

PROPOSITION 2.2. *Consider two vectors $v_i, i = 1, 2$, with angles θ_i satisfying $0 \leq \theta_1 < \theta_2 < \pi$. If the inequalities (1), (2) of Lemma 2.1 hold, then the lattice $G(v_1, v_2)$ admits the own vectors v_1, v_2 as canonical representatives.*

Proof. Let $M = \text{Max}\{\|v_1\|, \|v_2\|\}$, and consider the straight line R_m (resp. S_m) through mv_1 (resp. mv_2) in the direction v_2 (resp. v_1), $m \in \mathbb{Z}$. Obviously, no canonical representatives can appear in the lines S_0 and R_0 , except v_1 and v_2 . By the inequalities in Lemma 2.1, the points $S_i \cap R_j$ cannot be canonical representatives for $i, j \in \{1, -1\}$. Even more, they lie outside $B(0, M)$ (at most, they can lie at the boundary of $B(0, M)$). As $B(0, M)$ is convex, $B(0, M) \cap R_1$ (resp. $B(0, M) \cap R_{-1}$) is a (maybe empty) open segment and its only possible point in $G(v_1, v_2)$ is v_1 (resp. $-v_1$). Analogously, $S_{\pm 1} \cap B(0, M) \cap G(v_1, v_2)$ contains at most $\pm v_2$, thus, there are canonical representatives neither on R_m nor on S_m for $|m| = 1$.

To conclude the proof, let us check that, if $M = \|v_1\|$, no canonical representative can exist at R_m for $|m| \geq 2$ (the reasoning for $M = \|v_2\|$ would be analogous with S_m). From a straightforward computation (see Lemma 2.3 below) the angle $\theta = \theta_2 - \theta_1$ satisfies $\theta \in [\frac{\pi}{3}, \frac{2\pi}{3}[$, and $d(R_0, R_1) = r_1 \sin \theta \geq \frac{\sqrt{3}}{2} r_1$.

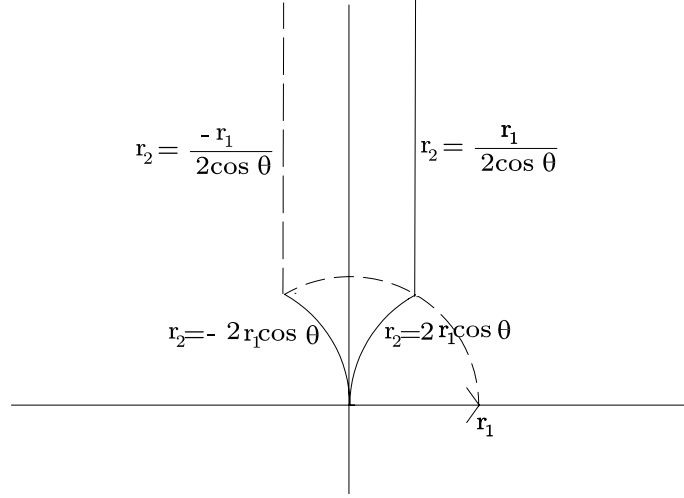

Figure 2: Limiting curves in Lemma 2.3.

Thus, if $u \in R_m$ with $|m| > 1$, then $d(0, u) \geq d(R_0, R_m) = |m|d(R_0, R_1) \geq |m|\frac{\sqrt{3}}{2}r_1 > r_1 = M$, and u cannot be a canonical representative. ■

Summing up, there exists a bijection between lattices and pairs (v_1, v_2) with $0 \leq \theta_1 < \theta_2 < \pi$ satisfying inequalities (1), (2) of Lemma 2.1. These inequalities are characterized in the following lemma, see Figure 2.

LEMMA 2.3. *Let $\{v_1, v_2\}$ be the two canonical representatives of a lattice.*

1. *Property (1) of Lemma 2.1 is equivalent to:*

$$\left\{ \begin{array}{l} (1A) \quad \theta \in]0, \min\{\pi - \theta_1, \frac{2\pi}{3}\}[, \\ (1B) \quad \text{If } \theta \in]\frac{\pi}{2}, \min\{\pi - \theta_1, \frac{2\pi}{3}\}[, \text{ then } -2r_1 \cos \theta \leq r_2 < \frac{-r_1}{2 \cos \theta}. \end{array} \right.$$

2. *Property (2) of Lemma 2.1 is equivalent to:*

$$\left\{ \begin{array}{l} (2A) \quad \theta \in [\frac{\pi}{3}, \pi - \theta_1[, \\ (2B) \quad \text{If } \theta \in [\frac{\pi}{3}, \min\{\frac{\pi}{2}, \pi - \theta_1\}[, \text{ then } 2r_1 \cos \theta \leq r_2 \leq \frac{r_1}{2 \cos \theta}, \\ \text{satisfying also: if } 2r_1 \cos \theta = r_2, \text{ then } \theta_1 < \frac{\pi}{3} \text{ and } \frac{\pi}{3} \leq \theta < \frac{\pi - \theta_1}{2}, \\ \text{if } r_2 = \frac{r_1}{2 \cos \theta}, \text{ then } \theta_1 < \theta < \frac{\pi}{2}. \end{array} \right.$$

Proof. 1. First, let $r = \|v_1 + v_2\|$. As $r^2 = r_1^2 + r_2^2 + 2r_1r_2 \cos \theta$, the two conditions in Property (1) (i.e., $r^2 \geq r_1^2$ and $r^2 > r_2^2$) are equivalent to:

$$\begin{cases} r_2 + 2r_1 \cos \theta \geq 0, \\ r_1 + 2r_2 \cos \theta > 0. \end{cases} \quad (1)$$

Thus, we will prove the equivalence between (1) and (1A), (1B).

(1) \Rightarrow (1A), (1B). Obviously, $\theta < \pi - \theta_1$. If $\cos \theta \geq 0$ then $\theta \in]0, \frac{\pi}{2}]$ and (1A), (1B) hold trivially. If $\cos \theta < 0$, then from (1) we have $r_2 \geq -2r_1 \cos \theta$ and $\frac{-r_1}{2\cos \theta} > r_2$. Thus, (1B) holds and:

$$-2 \cos \theta < \frac{-1}{2 \cos \theta} \quad (2)$$

Therefore, $\cos^2 \theta < \frac{1}{4}$, that is $\theta \in]\frac{\pi}{2}, \min\{\pi - \theta_1, \frac{2\pi}{3}\}[$.

(1A), (1B) \Rightarrow (1). When $\theta \in]0, \frac{\pi}{2}]$ inequalities (1) hold trivially. When (1A), (1B) hold with $\theta \in]\frac{\pi}{2}, \min\{\pi - \theta_1, \frac{2\pi}{3}\}[$, (2) clearly holds. Thus, the two inequalities in (1B) make sense, and each one of them implies one in (1).

2. Putting $r = \|v_1 - v_2\|$, the inequalities for $\|v_1 - v_2\| \geq \|v_i\|$ are equivalent to

$$\begin{cases} r_2 - 2r_1 \cos \theta \geq 0, \\ r_1 - 2r_2 \cos \theta \geq 0. \end{cases} \quad (3)$$

Then, the proof of (2A) and the inequalities of (2B) are analogous to the previous case, taking into account that, now, (3) holds trivially if $\cos \theta \leq 0$, that is, $\theta \in [\frac{\pi}{2}, \pi - \theta_1[$.

For the discussion of the equalities, let v_1, v_2 be two vectors with $0 \leq \theta_1 < \theta_2 < \pi$ satisfying Lemma 2.3(2B). Clearly it is enough to prove:

(a) If $r_2 = 2r_1 \cos \theta$, then: $(v_2)_y > (v_1)_y \Leftrightarrow \theta_1 < \frac{\pi}{3}$ and $\frac{\pi}{3} \leq \theta < \frac{\pi - \theta_1}{2}$,

(b) If $r_2 = \frac{r_1}{2 \cos \theta}$, then: $(v_2)_y > (v_1)_y \Leftrightarrow \theta_1 < \theta < \frac{\pi}{2}$.

For (a) as $(v_i)_y = r_i \sin \theta_i$, if $r_2 = 2r_1 \cos \theta$, inequality $(v_2)_y > (v_1)_y$ is equivalent to:

$$2r_1 \cos \theta \sin(\theta + \theta_1) > r_1 \sin \theta_1. \quad (4)$$

Putting $\cos \theta = t$, $t \in]0, \frac{1}{2}]$, using $0 \leq \sin \theta = \sqrt{1 - t^2}$ and expanding (4):

$$4t^4 - 4t^2 + \sin^2 \theta_1 < 0. \quad (5)$$

It is straightforward to check that inequalities $\theta_1 < \frac{\pi}{3}$, $\frac{\pi}{3} \leq \theta < \frac{\pi - \theta_1}{2}$ imply (5). Thus, the required implication to the left in (a) is obtained. For the converse, recall that the possible positive roots for the equality in (5) are

$t = \cos \theta = \sqrt{\frac{1 - \cos \theta_1}{2}} = \sin \frac{\theta_1}{2}$ and $\cos \theta = \sqrt{\frac{1 + \cos \theta_1}{2}} = \cos \frac{\theta_1}{2}$. As $t \in]0, \frac{1}{2}]$, and inequality (5) does not hold for $t = 0$, this inequality will hold only if at least one of the roots lies in the interval $]0, \frac{1}{2}[$. But this cannot hold for the second root, because the condition $\cos \frac{\theta_1}{2} < \frac{1}{2}$ implies $\theta_1 > \frac{2\pi}{3}$, in contradiction with $\theta + \theta_1 < \pi$.

Therefore, the first root will lie in the interval. The condition $\sin \frac{\theta_1}{2} < \frac{1}{2}$ implies $\theta_1 < \frac{\pi}{3}$. Moreover, in this case the possible solution of the equality in (5) would be $t \in]\sin \frac{\theta_1}{2}, \frac{1}{2}]$ or, equally, $\frac{\pi}{3} \leq \theta < \frac{\pi - \theta_1}{2}$, as required.

For (b), if $r_2 = \frac{r_1}{2 \cos \theta}$, inequality $(v_2)_y > (v_1)_y$ is equivalent to:

$$\frac{r_1}{2 \cos \theta} \sin(\theta + \theta_1) > r_1 \sin \theta_1.$$

Again, the implication to the left in (b) is then straightforward. For the converse, expanding the inequality, $\sin(\theta - \theta_1) > 0$. Thus, $\theta > \theta_1$ and, as $\theta < \frac{\pi}{2}$ is obvious, the required inequalities are obtained. ■

2.2. POINT SET IDENTIFICATION. Notice that, from Lemma 2.3 (1A), (2A), necessarily $\theta \in [\frac{\pi}{3}, \min\{\pi - \theta_1, \frac{2\pi}{3}\}]$, and as $\theta_2 = \theta_1 + \theta < \pi$ we have $\theta_1 < \frac{2\pi}{3}$. Fixed v_1 , the possible values for θ and r_2 are delimited by (1A), (1B), (2A), (2B) and, thus, r_1, θ_1 fix a region R_{r_1, θ_1} of the plane for the possible values of v_2 , represented by θ and r_2 . In order to discuss systematically all the possible cases, let us introduce the following definition.

DEFINITION 2.4. For each $v_1 \equiv (r_1, \theta_1)$ with $r_1 \in \mathbb{R}^+$ and $\theta_1 \in [0, \frac{2\pi}{3}[$ define R_{r_1, θ_1} as the set containing the vectors $v_2 \equiv (r_2, \theta_2)$ such that $r_2 > 0$ and $\theta_2 = \theta_1 + \theta$ satisfy:

$$\text{For } 0 \leq \theta_1 < \frac{\pi}{3}, \text{ alternatively } \left\{ \begin{array}{l} \frac{\pi}{3} \leq \theta < \frac{\pi - \theta_1}{2} \text{ and } 2r_1 \cos \theta \leq r_2 \leq \frac{r_1}{2 \cos \theta}, \\ \frac{\pi - \theta_1}{2} \leq \theta < \frac{\pi}{2} \text{ and } 2r_1 \cos \theta < r_2 \leq \frac{r_1}{2 \cos \theta}, \\ \theta = \frac{\pi}{2} \text{ and } r_2 \in \mathbb{R}^+, \\ \frac{\pi}{2} < \theta < \frac{2\pi}{3} \text{ and } -2r_1 \cos \theta \leq r_2 < \frac{-r_1}{2 \cos \theta}. \end{array} \right.$$

$$\text{For } \frac{\pi}{3} \leq \theta_1 < \frac{\pi}{2}, \text{ alternatively } \left\{ \begin{array}{l} \frac{\pi}{3} < \theta \leq \theta_1 \text{ and } 2r_1 \cos \theta < r_2 < \frac{r_1}{2 \cos \theta}, \\ \theta_1 < \theta < \frac{\pi}{2} \text{ and } 2r_1 \cos \theta < r_2 \leq \frac{r_1}{2 \cos \theta}, \\ \theta = \frac{\pi}{2} \text{ and } r_2 \in \mathbb{R}^+, \\ \frac{\pi}{2} < \theta < \pi - \theta_1 \text{ and } -2r_1 \cos \theta \leq r_2 < \frac{-r_1}{2 \cos \theta}. \end{array} \right.$$

$$\text{For } \frac{\pi}{2} \leq \theta_1 < \frac{2\pi}{3} : \frac{\pi}{3} < \theta < \pi - \theta_1 \text{ and } 2r_1 \cos \theta < r_2 < \frac{r_1}{2 \cos \theta}.$$

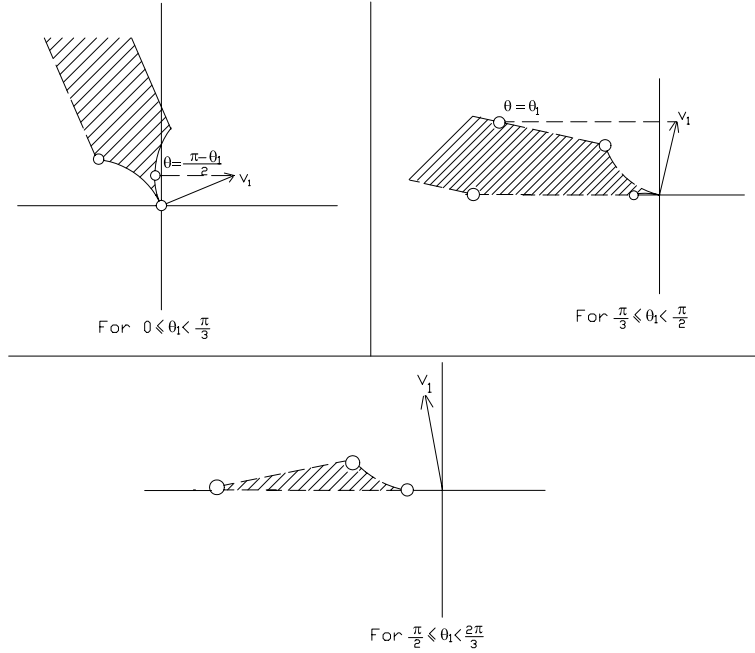

Figure 3: Regions R_{r_1, θ_1} in Definition 2.4.

The different cases for the sets R_{r_1, θ_1} are depicted in Figure 3.

PROPOSITION 2.5. *The map from the set of all the flat Riemannian torus $Gl^+(2, \mathbb{R})/Sl(2, \mathbb{Z})$ to the set $X = \{(r_1, \theta_1, r_2, \theta_2) : r_1 \in \mathbb{R}^+, \theta_1 \in [0, \frac{2\pi}{3}[$ and $(r_2, \theta_2) \in R_{r_1, \theta_1}\}$ which assigns to each torus T_G the value of $(r_1, \theta_1, r_2, \theta_2)$ corresponding to the canonical representatives of the lattice G , is a point bijection.*

Proof. As we have seen, $\theta_1 \in [0, \frac{2\pi}{3}[$ and $\theta \in [\frac{\pi}{3}, \min\{\pi - \theta_1, \frac{2\pi}{3}\}]$. Lemma 2.3 (1A), (1B) suggest to distinguish the two possible values of $\min\{\pi - \theta_1, \frac{2\pi}{3}\}$, that is, when inequality $\theta_1 < \frac{\pi}{3}$ holds or not. Moreover, (2B) suggests to distinguish when $\theta_1 < \frac{\pi}{2}$ holds.

In the case $0 \leq \theta_1 < \frac{\pi}{3}$, from (1A), (2A), $\theta \in [\pi/3, 2\pi/3[$ and we distinguish the subcases:

(a) $\frac{\pi}{3} \leq \theta < \frac{\pi - \theta_1}{2}$. By Lemma 2.3(2B) we have $2r_1 \cos \theta \leq r_2 \leq \frac{r_1}{2 \cos \theta}$. Notice that both equalities may hold, because $\theta < \frac{\pi - \theta_1}{2}$ and $\theta > \theta_1$.

(b) $\frac{\pi-\theta_1}{2} \leq \theta < \frac{\pi}{2}$. By the same Lemma, the same inequalities hold but the first strictly because of (2B), that is: $2r_1 \cos \theta < r_2 \leq \frac{r_1}{2 \cos \theta}$.

(c) $\theta = \frac{\pi}{2}$. There is no restriction for r_2 .

(d) $\frac{\pi}{2} < \theta < \frac{2\pi}{3}$. By 2.3(1B), inequality $-2r_1 \cos \theta \leq r_2 < \frac{-r_1}{2 \cos \theta}$ is obtained.

In the case $\frac{\pi}{3} \leq \theta_1 < \frac{\pi}{2}$, again (1A), (2A) imply $\theta \in [\pi/3, 2\pi/3[$, but now (2B) does not permit $\theta = \pi/3$. That is, $\theta \in]\pi/3, 2\pi/3[$, and we distinguish the subcases:

(a') $\frac{\pi}{3} < \theta \leq \theta_1$. By Lemma 2.3(2B) we have $2r_1 \cos \theta \leq r_2 \leq \frac{r_1}{2 \cos \theta}$, but none of the equalities can hold, because otherwise the contradiction $\theta_1 < \frac{\pi}{3}$ or $\theta_1 < \theta$ is yielded.

(b') $\theta_1 < \theta < \frac{\pi}{2}$. By Lemma 2.3(2B) we have $2r_1 \cos \theta \leq r_2 \leq \frac{r_1}{2 \cos \theta}$, but, as in previous case, the first equality cannot hold (the second one can).

(c') $\theta = \frac{\pi}{2}$. There is no restriction for r_2 .

(d') $\frac{\pi}{2} < \theta < \pi - \theta_1$. As $\pi - \theta_1 \leq \frac{2\pi}{3}$, Lemma 2.3(1B) yields the required inequalities.

In the case $\frac{\pi}{2} \leq \theta_1 < \frac{2\pi}{3}$, reasoning as in previous case for θ_1 , necessarily $\theta \in]\frac{\pi}{3}, \frac{2\pi}{3}[$. Even more, as $\theta + \theta_1 < \pi$, one has $\theta < \frac{\pi}{2}$ and the restrictions for (r_2, θ_2) lie under (2B). ■

2.3. MANIFOLD STRUCTURE: IDENTIFICATIONS. Up to now, the bijection between the quotient set $Gl^+(2, \mathbb{R})/Sl(2, \mathbb{Z})$ and X has been defined at a point-set level. In order to obtain a homeomorphism, a topology will be defined in X by enlarging it with the points in the boundary (endowed with the natural topology), and identifying suitable boundary points.

More precisely, let $\overset{\circ}{R}_{r_1, \theta_1}$ be the interior in \mathbb{R}^2 of R_{r_1, θ_1} , and let $\overset{\circ}{X} = \{(v_1, v_2) \equiv (r_1, \theta_1, r_2, \theta_2) : r_1 > 0, \theta_1 \in]0, \frac{2\pi}{3}[, (r_2, \theta_2) \in \overset{\circ}{R}_{r_1, \theta_1}\}$. Let \bar{X} be its closure in $(\mathbb{R}^+ \times \mathbb{R})^2$, endowed with its natural topology. Our aims are: (1) to define four identifications between points in $\partial X = \bar{X} \setminus \overset{\circ}{X}$, which determine a relation of equivalence, (2) to show that each class of equivalence contains one and only one representative in X , and (3) to prove that the quotient topological space $\tilde{X} = \bar{X} / \sim$ is homeomorphic to $Gl^+(2, \mathbb{R})/Sl(2, \mathbb{Z})$.

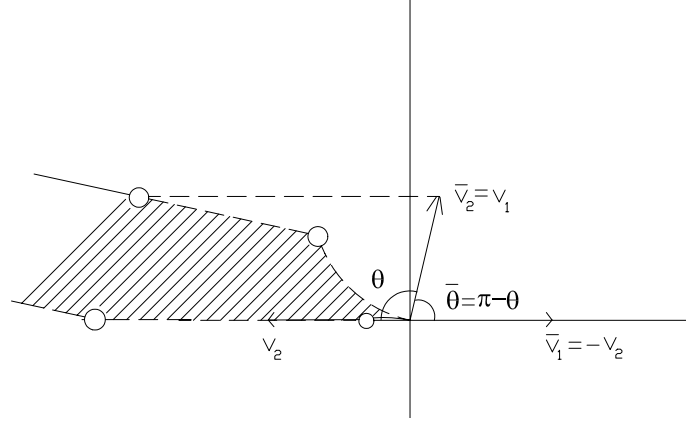

Figure 4: Identification I, representatives (v_1, v_2) are identified with the canonical ones (\bar{v}_1, \bar{v}_2) , being $\bar{v}_1 = -v_2$ and $\bar{v}_2 = v_1$.

Next, identify a pair $(v_1, v_2) \in (\partial X) \setminus X$ with $(\bar{v}_1, \bar{v}_2) \in \partial X$ (which may or not lie in X) according to the following rules (we use still $v_i \equiv (r_i, \theta_i)$, $\bar{v}_i \equiv (\bar{r}_i, \bar{\theta}_i)$, $\theta = \theta_2 - \theta_1$, $\bar{\theta} = \bar{\theta}_2 - \bar{\theta}_1$):

- I. If $\theta_2 = \pi$ (and, thus, by Definition 2.4, $\theta_1 \geq \frac{\pi}{3}$, see Figure 2):

$$(r_1, \theta_1, r_2, \pi) \sim (r_2, 0, r_1, \theta_1).$$

This identification is suggested because v_2 in a canonical representative cannot lie in the negative x -semiaxis and, then, it can be replaced by $-v_2$. But, as $-v_2$ lies in the positive x -semiaxis, it will be ordered before v_1 , i.e., $\bar{v}_1 = -v_2$, $\bar{v}_2 = v_1$, being $\bar{\theta} = \pi - \theta$.

In order to check that $\bar{v}_2 \in \bar{R}_{\bar{r}_1, 0}$ ($(\bar{v}_1, \bar{v}_2) \in \bar{X}$) and discuss when it belongs to $R_{\bar{r}_1, 0}$ ($(\bar{v}_1, \bar{v}_2) \in X$), consider the following cases for (v_1, v_2) according to Definition 2.4:

(a) $\frac{\pi}{3} \leq \theta_1 < \frac{\pi}{2}$ and $-2r_1 \cos(\pi - \theta_1) \leq r_2 \leq \frac{-r_1}{2 \cos(\pi - \theta_1)}$, that is, $2r_1 \cos \theta_1 \leq r_2 \leq \frac{r_1}{2 \cos \theta_1}$ (Figure 2). As $\bar{r}_1 = r_2$, $\bar{r}_2 = r_1$, $\bar{\theta} = \theta_1$, necessarily $\frac{\pi}{3} \leq \bar{\theta} < \frac{\pi}{2}$ and $2\bar{r}_1 \cos \bar{\theta} \leq \bar{r}_2 \leq \frac{\bar{r}_1}{2 \cos \bar{\theta}}$. Thus, $\bar{v}_2 \in R_{\bar{r}_1, 0}$.

(b) If $\frac{\pi}{2} \leq \theta_1 \leq \frac{2\pi}{3}$ and $2r_1 \cos(\pi - \theta_1) \leq r_2 \leq \frac{r_1}{2 \cos(\pi - \theta_1)}$ (Figure 3), one has analogously $\bar{v}_2 \in \bar{R}_{\bar{r}_1, 0}$ and, if the inequality $2r_1 \cos(\pi - \theta_1) \leq r_2$ holds strictly, then $\bar{v}_2 \in R_{\bar{r}_1, 0}$.

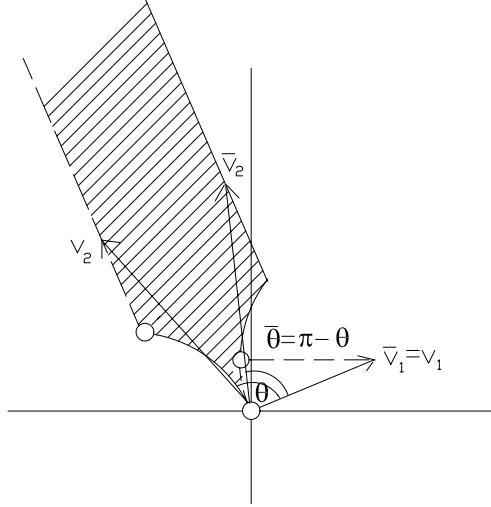

Figure 5: Identification II, ($\bar{v}_1 = v_1, \bar{v}_2 = v_1 + v_2$).

II. If $r_2 = \frac{-r_1}{2 \cos \theta}$ (and, thus, as limit cases of the strict inequality $r_2 < \frac{-r_1}{2 \cos \theta}$ in Definition 2.4, necessarily $\theta_1 < \frac{\pi}{2}$ and $\frac{\pi}{2} < \theta \leq \min\{\pi - \theta_1, \frac{2\pi}{3}\}$, Figure 3):

$$(r_1, \theta_1, \frac{-r_1}{2 \cos \theta}, \theta_1 + \theta) \sim (r_1, \theta_1, \frac{-r_1}{2 \cos \theta}, \theta_1 + \pi - \theta).$$

This identification is suggested because, for such (non canonical) representatives (v_1, v_2) , one has $\|v_1 + v_2\| = \|v_2\|$ and, then, one can take instead $\bar{v}_1 = v_1, \bar{v}_2 = v_1 + v_2$. In this case $\|v_2\| = \frac{-\|v_1\|}{2 \cos \theta}$. Even more, $\cos \bar{\theta} = \frac{\bar{v}_1 \bar{v}_2}{\|\bar{v}_1\| \|\bar{v}_2\|} = \frac{v_1(v_1+v_2)}{\|v_1\| \|v_1+v_2\|} = \frac{\|v_1\|}{\|v_2\|} + \cos \theta = \frac{\|v_1\|}{\frac{-\|v_1\|}{2 \cos \theta}} + \cos \theta = -\cos \theta$, and, therefore, $\bar{\theta} = \pi - \theta$.

In order to check $\bar{v}_2 \in \partial R_{\bar{r}_1, \bar{\theta}_1}$ notice just that \bar{v}_2 is symmetric in respect to the axis $\theta = \frac{\pi}{2}$ for v_2 in the domain R_{r_1, θ_1} , and $\partial R_{\bar{r}_1, \bar{\theta}_1}$ is also symmetric in respect to this axis. To discuss when $\bar{v}_2 \in R_{\bar{r}_1, \bar{\theta}_1}$ recall:

(a) If $0 \leq \theta_1 < \frac{\pi}{3}$ clearly $\bar{v}_2 \in R_{\bar{r}_1, \bar{\theta}_1}$,

and

(b) If $\frac{\pi}{3} \leq \theta_1 < \frac{\pi}{2}$, then $\frac{\pi}{2} < \theta \leq \pi - \theta_1$, thus, $\theta_1 \leq \pi - \theta < \frac{\pi}{2}$, i.e., $\theta_1 \leq \bar{\theta} < \frac{\pi}{2}$. Now, when $\bar{\theta} > \theta_1$, we have $\bar{v}_2 \in R_{\bar{r}_1, \bar{\theta}_1}$, otherwise ($\bar{\theta} = \theta_1$) this does not hold.

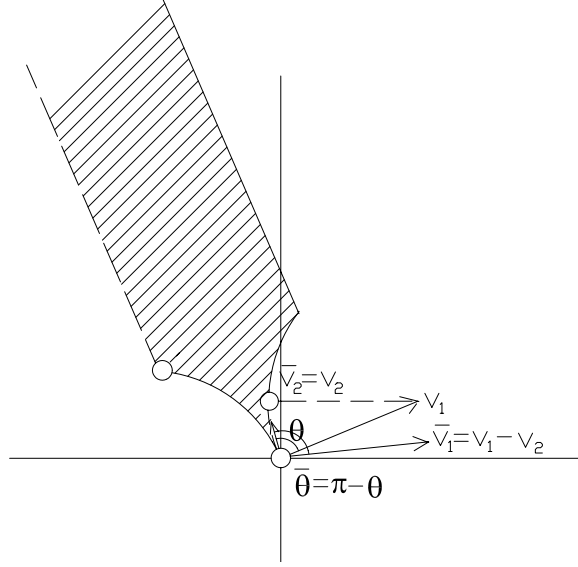

Figure 6: Identification III, ($\bar{v}_1 = v_1 - v_2$, $\bar{v}_2 = v_2$).

- III. For $r_2 = 2r_1 \cos \theta$ (and, thus, either $0 \leq \theta_1 < \frac{\pi}{3}$ with $\frac{\pi - \theta_1}{2} \leq \theta < \frac{\pi}{2}$, or $\frac{\pi}{3} \leq \theta_1 < \frac{\pi}{2}$ with $\frac{\pi}{3} \leq \theta < \frac{\pi}{2}$, or $\frac{\pi}{2} \leq \theta_1 \leq \frac{2\pi}{3}$ with $\frac{\pi}{3} \leq \theta \leq \pi - \theta_1$; see Figure 3):

$$(r_1, \theta_1, 2r_1 \cos \theta, \theta_1 + \theta) \sim (r_1, \theta_1 + 2\theta - \pi, 2r_1 \cos \theta, \theta_1 + \theta).$$

This is suggested because, in this case, $\|v_1 - v_2\| = \|v_1\|$ and we can take $\bar{v}_1 = v_1 - v_2$, $\bar{v}_2 = v_2$. In this case, $\cos \bar{\theta} = \frac{\bar{v}_1 \bar{v}_2}{\|\bar{v}_1\| \|\bar{v}_2\|} = \frac{(v_1 - v_2)v_2}{\|v_1 - v_2\| \|v_2\|} = \cos \theta - \frac{\|v_2\|}{\|v_1\|} = \cos \theta - \frac{2\|v_1\| \cos \theta}{\|v_1\|} = -\cos \theta$, and, therefore, $\bar{\theta} = \pi - \theta$. Even more, $\bar{\theta}_1 = \bar{\theta}_2 - \bar{\theta} = \theta_2 - (\pi - \theta) = \theta_1 + \theta - \pi + \theta = \theta_1 + 2\theta - \pi$.

In order to check $\bar{v}_2 \in \partial R_{\bar{r}_1, \bar{\theta}_1}$, notice that, when $\frac{\pi}{3} < \theta < \pi - \theta_1$ ($\theta_2 < \pi$), necessarily $\bar{v}_2 \in \partial R_{\bar{r}_1, \bar{\theta}_1} \cap R_{\bar{r}_1, \bar{\theta}_1}$. In fact, as $\|\bar{v}_1 + \bar{v}_2\| = \|v_1\| = \|\bar{v}_1\|$, one has $\bar{r}_2 = r_2 = 2r_1 \cos \theta = -2r_1 \cos \bar{\theta} = -2\bar{r}_1 \cos \bar{\theta}$. Otherwise, in the limit cases $\theta = \pi - \theta_1$, or $\theta = \frac{\pi}{3}$ clearly $\bar{v}_2 \in \partial R_{\bar{r}_1, \bar{\theta}_1}$ and does not belong to $R_{\bar{r}_1, \bar{\theta}_1}$.

- IV. For $r_2 = \frac{r_1}{2 \cos \theta}$ (and, thus, either $\frac{\pi}{3} \leq \theta_1 < \frac{\pi}{2}$ with $\frac{\pi}{3} \leq \theta \leq \theta_1$ or $\frac{\pi}{2} \leq \theta_1 \leq \frac{2\pi}{3}$ with $\frac{\pi}{3} \leq \theta \leq \pi - \theta_1$; see Figure 3):

$$(r_1, \theta_1, \frac{r_1}{2 \cos \theta}, \theta_1 + \theta) \sim (\frac{r_1}{2 \cos \theta}, \theta_1 - \theta, r_1, \theta_1).$$

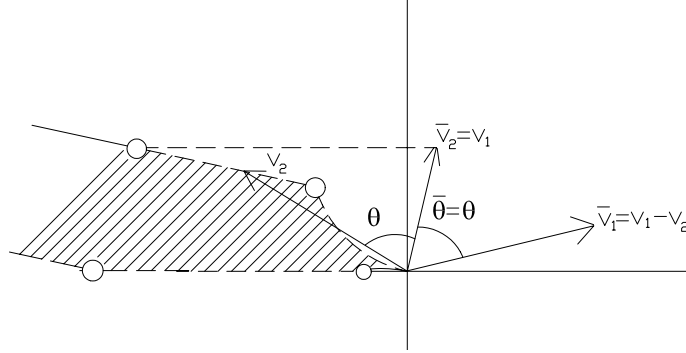

Figure 7: Identification IV, ($\bar{v}_1 = v_1 - v_2$, $\bar{v}_2 = v_1$).

This is suggested because $\|v_1 - v_2\| = \|v_2\|$ and we can take $\bar{v}_1 = v_1 - v_2$, $\bar{v}_2 = v_1$. In this case $\cos \bar{\theta} = \frac{\bar{v}_1 \bar{v}_2}{\|\bar{v}_1\| \|\bar{v}_2\|} = \frac{(v_1 - v_2)v_1}{\|v_1 - v_2\| \|v_1\|} = \frac{\|v_1\|}{\|v_2\|} - \cos \theta = \frac{\|v_1\|}{2 \cos \theta} - \cos \theta = \cos \theta$. Therefore, $\bar{\theta} = \theta$, and $\bar{\theta}_1 = \bar{\theta}_2 - \bar{\theta} = \theta_1 - \theta$.

Notice that, in this case, the point $E = (r_1, \frac{\pi}{3}, r_1, \frac{2\pi}{3})$ is identifiable with $E_{IV} = (r_1, 0, r_1, \frac{\pi}{3})$ if E is regarded on the left-hand side of the identification, and with $E'_{IV} = (r_1, \frac{2\pi}{3}, r_1, \pi)$ if E is on the right-hand one. (This property only happens in this case.)

To check $\bar{v}_2 \in \partial R_{\bar{r}_1, \bar{\theta}_1}$, notice that $\|\bar{v}_1 - \bar{v}_2\| = \|-v_2\| = \|\bar{v}_1\|$. Thus, $r_2 = \frac{r_1}{2 \cos \theta}$ and $\bar{r}_2 = r_1 = 2r_2 \cos \theta = 2\bar{r}_1 \cos \bar{\theta}$, and the result follows.

To discuss when $\bar{v}_2 \in R_{\bar{r}_1, \bar{\theta}_1}$:

- (a) When $\frac{\pi}{3} \leq \theta_1 < \frac{\pi}{2}$ and $\frac{\pi}{3} \leq \theta \leq \theta_1$, necessarily, $\bar{\theta}_1 = \theta_1 - \theta < \frac{\pi}{6}$ and $\frac{\pi}{3} \leq \bar{\theta} < \frac{\pi}{2}$. Thus, $\bar{v}_2 \in R_{\bar{r}_1, \bar{\theta}_1}$ if $\bar{\theta} < \frac{\pi - \bar{\theta}_1}{2}$ (or, equally, if $\theta < \pi - \theta_1$).
- (b) When $\frac{\pi}{2} \leq \theta_1 \leq \frac{2\pi}{3}$ and $\frac{\pi}{3} \leq \theta \leq \pi - \theta_1$, necessarily $\bar{\theta}_1 \leq \frac{\pi}{3}$ and $\frac{\pi}{3} \leq \bar{\theta} \leq \frac{\pi}{2}$. In this case, $\bar{\theta} \leq \frac{\pi - \bar{\theta}_1}{2}$, and $\bar{v}_2 \in R_{\bar{r}_1, \bar{\theta}_1}$, if the inequality is strict.

The four identifications above induce a relation of equivalence in \bar{X} , by assuming that the identifications are transitive. We will say that $P, Q \in \bar{X}$ are *directly related* if they are identified through one of the four identifications; otherwise, P and Q maybe related through a chain $P = P_1 \sim P_2 \sim \dots \sim P_{l-1} \sim P_l = Q$, $l \geq 3$. As we will see in Lemma 2.7, no chains with length $l > 3$ will be necessary.

Our aim is to show that any class has one and only one element of X .

LEMMA 2.6. *Each element of $(\partial X) \setminus X$ is identified with at least one element of X .*

Proof. Looking at the discussion on where lies \bar{v}_2 in each case, when $\theta_2 < \pi$ and $\theta \neq \frac{\pi}{3}$ one has directly $\bar{v}_2 \in R_{\bar{r}_1, \bar{\theta}_1}$, that is, $(\bar{v}_1, \bar{v}_2) \in X$.

When $\theta_2 = \pi$, the point (\bar{v}_1, \bar{v}_2) obtained after applying either I, II, III, or IV does not belong to X , but then the further identification II, IV, I and III, respectively, matches (\bar{v}_1, \bar{v}_2) with a point in X .

When $\theta = \frac{\pi}{3}$, identification III matches (v_1, v_2) with a point $(\bar{v}_1, \bar{v}_2) \in \partial X$. Then, identification II matches (\bar{v}_1, \bar{v}_2) with a point in X . ■

LEMMA 2.7. *Each class of equivalence contains at most one element of X .*

Proof. The proof is carried out by discussing exhaustively the number and type of the elements at each class. Consider a point $(v_1, v_2) \in \partial X$ which is directly related to $n = 0, \dots, 4$ points, and discuss the cases:

$$\begin{array}{ccc}
 A & \xrightarrow{III} & \mathbf{A}_{III} \\
 IV \searrow & & \nearrow I \\
 & & A_{IV}
 \end{array}$$

$$\begin{array}{ccc}
 B & \xrightarrow{IV} & \mathbf{B}_{IV} \\
 II \searrow & & \nearrow I \\
 & & B_{II}
 \end{array}$$

$$\begin{array}{ccc}
 L & \xrightarrow{III} & L_{III} \\
 IV \searrow & & \nearrow II \\
 & & \mathbf{L}_{IV}
 \end{array}$$

$$\begin{array}{ccc}
 T & \xrightarrow{III} & T_{III} \\
 I \downarrow & & \downarrow I \\
 T_I & \xrightarrow{II} & \mathbf{T}'
 \end{array}$$

$$\begin{array}{ccccc}
 & & E_{III} & & \\
 & I \nearrow & \uparrow III & \searrow & II \\
 E'_{IV} & \xrightarrow{IV} & E & \xrightarrow{IV} & \mathbf{E}_{IV} \\
 & III \searrow & \downarrow II & \nearrow & I \\
 & & E_{II} & &
 \end{array}$$

- $n = 4$. The four identifications are not applicable to any point of \bar{X} at the same time. However, the point $E = (r_1, \frac{\pi}{3}, r_1, \frac{2\pi}{3})$, for any $r_1 > 0$, is directly identified with four points $[E] = \{E, E_{II}, E_{III}, E_{IV}, E'_{IV}\}$, being $E_{II} = (r_1, \frac{\pi}{3}, r_1, \pi)$, $E_{III} = (r_1, 0, r_1, \frac{2\pi}{3})$, $E_{IV} = (r_1, 0, r_1, \frac{\pi}{3})$ and $E'_{IV} = (r_1, \frac{2\pi}{3}, r_1, \pi)$. These are the unique classes with four elements, and the unique representative of $[E]$ in X is E_{IV} .
- $n = 3$. No point is directly related with three points exactly.
- $n = 2$. There are four possible classes, three of them with three elements each one, and the other class with four elements:
 - $[A] = \{A, A_{III}, A_{IV}\}$, where $A = (r_1, \theta_1, 2r_1 \cos(\frac{\pi-\theta_1}{2}), \frac{\pi+\theta_1}{2})$ with $\theta_1 < \frac{\pi}{3}$. Here A_{III} and A_{IV} are the points obtained by the identifications III, IV, resp., and the unique element in X is $A_{III} = (r_1, 0, 2r_1 \cos(\frac{\pi-\theta_1}{2}), \frac{\pi+\theta_1}{2})$.
 - $[B] = \{B, B_{II}, B_{IV}\}$, where $B = (r_1, \theta_1, \frac{r_1}{2 \cos \theta_1}, 2\theta_1)$ with $\frac{\pi}{3} < \theta_1 < \frac{\pi}{2}$. Here, B_{II}, B_{IV} are obtained by means of II, IV, and the unique element in X is $B_{IV} = (\frac{r_1}{2 \cos \theta_1}, 0, r_1, \theta_1)$.
 - $[L] = \{L, L_{III}, L_{IV}\}$, where $L = (r_1, \theta_1, r_1, \theta_1 + \frac{\pi}{3})$ with $\theta_1 > \frac{\pi}{3}$. Here, L_{III} and L_{IV} are obtained by means of III, IV, and the unique element in X is $L_{IV} = (r_1, \theta_1 - \frac{\pi}{3}, r_1, \theta_1)$.
 - $[T] = \{T, T_I, T', T_{III}\}$, where $T = (r_1, \theta_1, 2r_1 \cos(\pi - \theta_1), \pi)$ with $\frac{\pi}{2} < \theta_1 < \frac{2\pi}{3}$. Here, T_I and T_{III} are obtained by means of I, III, and the unique element in X is $T' = (2r_1 \cos(\pi - \theta_1), 0, r_1, \theta_1)$.
- $n = 1$. The class contains two points P, P' , one of them in X (because each class contains at least one element of X by Lemma 2.6, and no direct relation identifies two points of X). Notice that if P is directly related only to P' , then P' cannot be directly related to more than one point, otherwise, it would lie in previous cases.
- $n = 0$. Obviously the class contains a unique point P , which satisfies $P \in X \setminus \partial X$. ■

Let \hat{X} be the quotient set of \bar{X} by the relation of equivalence \sim , endowed with the quotient topology. Given $(v_1, v_2) \in \bar{X}$, its class will be denoted $[(v_1, v_2)] \in \hat{X}$.

PROPOSITION 2.8. *The map $F : Gl^+(2, \mathbb{R})/Sl(2, \mathbb{Z}) \longrightarrow \hat{X}$ which maps each lattice to the class of its canonical representatives, is a homeomorphism.*

Proof. For the continuity of F , consider the following diagram, where π^+ , $\hat{\pi}$ denote the canonical projections:

$$\begin{array}{ccc} & \bar{X} & \\ \pi^+ \swarrow & & \searrow \hat{\pi} \\ Gl^+(2, \mathbb{R})/Sl(2, \mathbb{Z}) & \xrightarrow{F} & \hat{X} \end{array}$$

F is continuous if and only if so is $F \circ \pi^+$, and this holds because the diagram is commutative, that is, this composition is equal to $\hat{\pi}$.

Analogously, for the continuity of F^{-1} , notice the following commutative diagram:

$$\begin{array}{ccc} Gl^+(2, \mathbb{R}) & \xleftarrow{i} & \bar{X} \\ \pi^+ \downarrow & \bar{F}^{-1} \swarrow \searrow \hat{\pi} & \\ Gl^+(2, \mathbb{R})/Sl(2, \mathbb{Z}) & \xleftarrow{F^{-1}} & \hat{X} \end{array}$$

where i is the canonical inclusion. Now, F^{-1} is continuous if and only if so is $\bar{F}^{-1} = F^{-1} \circ \hat{\pi} = \pi^+ \circ i$ -this last composition continuous, as required. ■

Remark 2.9. As $Gl^+(2, \mathbb{R})/Sl(2, \mathbb{Z})$ has a natural structure of smooth manifold, F induces a differentiable structure on \hat{X} . Such structure will be regarded as the canonical differentiable structure of \hat{X} . Nevertheless, recall that the cut and paste construction of \hat{X} also permits to construct such a structure “by hand” in an obvious way.

3. MANIFOLDS OF CLASSES OF RIEMANNIAN TORI

We will study the structure of quotient spaces $G_H = H \backslash (Gl^+(2, \mathbb{R})/Sl(2, \mathbb{Z}))$ where H is each of the following subgroups of $Gl(2, \mathbb{R})$:

$$\begin{aligned} O(2, \mathbb{R}) &= \{A \in Gl(2, \mathbb{R}) : AA^t = I_2\}, \\ O^+(2, \mathbb{R}) &= O(2, \mathbb{R}) \cap Gl^+(2, \mathbb{R}), \\ CO(2, \mathbb{R}) &= \{A \in Gl(2, \mathbb{R}) : AA^t = aI_2, a > 0\}, \\ CO^+(2, \mathbb{R}) &= CO(2, \mathbb{R}) \cap Gl^+(2, \mathbb{R}). \end{aligned}$$

(I_2 denotes the identity matrix 2×2). Such quotients will admit natural structures of either orbifolds or smooth manifolds with piecewise smooth boundary. For the former, the reader can look at abundant literature, as the recent articles [4], [5] and references therein. Nevertheless, for our purposes, more

simple and intuitive references, as classical Thurston’s notes [13] (where the name “orbifold” is introduced) or the seminal paper by Satake [12] (where they are defined for the first time with the name “V-manifolds”) are enough. For the latter, we introduce some notation. Consider the closed quadrant $D^n = \{(x_1, \dots, x_n) : 0 \leq x_i, \text{ for all } i\} \subset \mathbb{R}^n$ with the induced topology. A (paracompact, Hausdorff) topological manifold with boundary M is a *smooth manifold with piecewise smooth boundary* if it is endowed with a maximal atlas \mathcal{A} with charts defined between open subsets $\phi_\alpha : W_\alpha \subset M \rightarrow U_\alpha \subset D^n$ and all the possible changes of charts $\phi_\beta \circ \phi_\alpha^{-1} : \phi_\alpha(U_\alpha \cap U_\beta) \rightarrow \phi_\beta(U_\alpha \cap U_\beta)$ are smooth in the ordinary sense. For such a manifold, $\partial_k M \subset M$, is defined as the set which contains all the points $p \in M$ such that exactly k coordinates of $\phi_\alpha(p)$ vanish (for one chart ϕ_α and, then, for any chart around p). For $k = 1, \dots, n$, $\partial_k M$ is called the k -edge of M ; for $k = 0$, the open set $\partial_0 M$, also denoted $\overset{\circ}{M}$, is called the *interior* (or set of smooth points) of M .

The following straightforward result will be used:

LEMMA 3.1. *Let A, B be topological spaces. Let \sim_A, \sim_B be relations of equivalence in A, B , resp. Consider the quotient sets $\hat{A} = A / \sim_A, \hat{B} = B / \sim_B$ with canonical projections π_A, π_B resp. Assume that $f : A \rightarrow B$ is continuous. If there exists a map $\hat{f} : \hat{A} \rightarrow \hat{B}$ which makes commutative the diagram (i.e., if $x \sim_A y$ implies $f(x) \sim_B f(y)$):*

$$\begin{array}{ccc} A & \xrightarrow{f} & B \\ \pi_A \downarrow & & \downarrow \pi_B \\ \hat{A} & \xrightarrow{\hat{f}} & \hat{B}, \end{array}$$

then \hat{f} is unique and continuous. Even more, if f is a homeomorphism (resp. onto), then \hat{f} is a homeomorphism (resp. onto).

3.1. CASE $H = O^+(2, \mathbb{R})$. In this case, two lattices are identified if and only if there exists an orientation-preserving isometry between the corresponding flat Riemannian tori. Our first aim is to prove:

PROPOSITION 3.2. *If $H = O^+(2, \mathbb{R})$, then G_H is homeomorphic to \mathbb{R}^3 .*

In the proof, a concrete homeomorphism with \mathbb{R}^3 is constructed and, thus one could induce in G_H a differentiable structure diffeomorphic to \mathbb{R}^3 . Nevertheless, the constructive cut-and-paste procedure plus the natural requirement on independence of the structure from the choice of canonical representatives, makes the orbifold structure asserted in Theorem 1.1 apparent.

In order to prove Proposition 3.2, consider the set

$$Y^+ = \{(r_1, 0, r_2, \theta_2) : r_1 \in \mathbb{R}^+, (r_2, \theta_2) \in R_{r_1, 0}\} \subset \bar{X}$$

and its closure \bar{Y}^+ in \bar{X} . Consider the map $\bar{\alpha}^+ : \bar{X} \rightarrow \bar{Y}^+$

$$\bar{\alpha}^+(v_1, v_2) = (M_{-\theta_1}(v_1), M_{-\theta_1}(v_2)), \quad (6)$$

where $M_{-\theta_1}$ is the rotation of angle $-\theta_1$ in \mathbb{R}^2 . This map, $\bar{\alpha}^+$ can be seen as a quotient projection on the topological space \bar{Y}^+ (i.e., \bar{Y}^+ can be seen as the topological space obtained by identifying the points in \bar{X} with the same image). In fact, $\bar{\alpha}^+$ is continuous, onto and, if $A \subset \bar{Y}^+$ satisfies that $(\bar{\alpha}^+)^{-1}(A)$ is open in \bar{X} , then A is open in \bar{Y}^+ .

Next, our aim is to define a relation of equivalence on \bar{Y}^+ such that the quotient set \hat{Y}^+ will be identified canonically with G_H . Consider the relation of equivalence in \bar{Y}^+ determined by the following identifications (each one justified because two canonical representatives identified by I, II, III or IV in \bar{X} , must have the same image by $\bar{\alpha}^+$ in \hat{Y}^+):

I'. For any $(r_1, 0, r_2, \theta) \in \bar{Y}^+$:

$$(r_1, 0, r_2, \theta) \sim (r_2, 0, r_1, \pi - \theta).$$

Justification: in the identification I, if $(r_1, \theta_1, r_2, \pi) \sim (r_2, 0, r_1, \theta_1)$, then

$$\bar{\alpha}^+(r_1, \theta_1, r_2, \pi) = (r_1, 0, r_2, \pi - \theta_1)$$

must be identified with

$$\bar{\alpha}^+(r_2, 0, r_1, \theta_1) = (r_2, 0, r_1, \theta_1).$$

II'. For $r_2 = \frac{-r_1}{2 \cos \theta}$, $\frac{\pi}{2} < \theta \leq \frac{2\pi}{3}$:

$$\left(r_1, 0, \frac{-r_1}{2 \cos \theta}, \theta\right) \sim \left(r_1, 0, \frac{-r_1}{2 \cos \theta}, \pi - \theta\right).$$

Justification: in II, if $(r_1, \theta_1, \frac{-r_1}{2 \cos \theta}, \theta_1 + \theta) \sim (r_1, \theta_1, \frac{-r_1}{2 \cos \theta}, \theta_1 + \pi - \theta)$, then

$$\bar{\alpha}^+\left(r_1, \theta_1, \frac{-r_1}{2 \cos \theta}, \theta_1 + \theta\right) = \left(r_1, 0, \frac{-r_1}{2 \cos \theta}, \theta\right)$$

must be identified with

$$\bar{\alpha}^+\left(r_1, \theta_1, \frac{-r_1}{2 \cos \theta}, \theta_1 + \pi - \theta\right) = \left(r_1, 0, \frac{-r_1}{2 \cos \theta}, \pi - \theta\right).$$

One could also consider the natural identifications:

III'. For $r_2 = 2r_1 \cos \theta$, $\frac{\pi}{3} \leq \theta < \frac{\pi}{2}$:

$$(r_1, 0, 2r_1 \cos \theta, \theta) \sim (r_1, 0, 2r_1 \cos \theta, \pi - \theta).$$

IV'. For $r_2 = \frac{r_1}{2 \cos \theta}$, $\frac{\pi}{3} \leq \theta < \frac{\pi}{2}$:

$$\left(r_1, 0, \frac{r_1}{2 \cos \theta}, \theta\right) \sim \left(\frac{r_1}{2 \cos \theta}, 0, r_1, \theta\right).$$

Nevertheless, III' and IV' can be obtained as suitable compositions of I' and II'; so, only I' and II' are truly relevant now.

The quotient set of \bar{Y}^+ by the identifications I' and II' (and then IV', III') will be denoted \hat{Y}^+ .

LEMMA 3.3. *The map $\hat{\alpha}^+ : \hat{X} \longrightarrow \hat{Y}^+$, which makes commutative the diagram*

$$\begin{array}{ccc} \bar{X} & \xrightarrow{\bar{\alpha}^+} & \bar{Y}^+ \\ \pi_X \downarrow & & \downarrow \pi_{Y^+} \\ \hat{X} & \xrightarrow{\hat{\alpha}^+} & \hat{Y}^+ \end{array}$$

is a quotient projection on the topological space \hat{Y}^+ (i.e., $\hat{\alpha}^+$ is onto and $\hat{A} \subset \hat{Y}^+$ is open if and only if $(\hat{\alpha}^+)^{-1}(\hat{A})$ is open).

Proof. Notice that $\hat{\alpha}^+$ must be defined as $\hat{\alpha}^+[(v_1, v_2)] = [\bar{\alpha}^+(v_1, v_2)]$, and this definition is consistent by the definition of identifications I', II', III', IV'. Thus, the result follows from Lemma 3.1 and the fact that $\bar{\alpha}^+$ is a quotient projection. ■

Our following result shows that \hat{Y}^+ is canonically identifiable to G_H .

LEMMA 3.4. *Let $\hat{F}^+ : G_H \longrightarrow \hat{Y}^+$ be the unique map which makes commutative the following diagram:*

$$\begin{array}{ccc} Gl^+(2, \mathbb{R})/Sl(2, \mathbb{Z}) & \xrightarrow{F} & \hat{X} \\ \searrow \pi & & \swarrow \hat{\alpha}^+ \\ G_H & \xrightarrow{\hat{F}^+} & \hat{Y}^+ \end{array}$$

Then, \hat{F}^+ is a homeomorphism.

Proof. In order to obtain a commutative diagram, we must define $\hat{F}^+[R] = [(\hat{\alpha}^+ \circ F)(R)]$, and prove that this is well-defined, i.e., if $R_1 \sim_H R_2$ then $[\hat{\alpha}^+[F(R_1)]] = [\hat{\alpha}^+[F(R_2)]]$.

If $R_1 \sim_H R_2$, we can assume $\hat{\alpha}^+ \circ F(R_1) = [(v_1, v_2)]$ with $v_1 = (r_1, 0)$, $v_2 = (r_2, \theta)$, $r_2 \geq r_1$, and $\hat{\alpha}^+ \circ F(R_2) = [(\bar{v}_1, \bar{v}_2)]$, with $\bar{v}_1 = (\bar{r}_1, 0)$, $\bar{v}_2 = (\bar{r}_2, \beta)$, $\bar{r}_2 \geq \bar{r}_1$ (by taking the appropriately rotated representatives of the class, and using eventually identification Γ). Let \bar{R}_i the lattice generated by $\hat{\alpha}^+ \circ F(R_i)$, $i = 1, 2$. As $\{r_1, r_2\}$ is invariant by rotations, necessarily $\bar{r}_i = r_i$, $i = 1, 2$ and, thus $\bar{v}_1 = v_1$. By the definition of $\hat{\alpha}^+$, one also has that an appropriate rotation of \bar{R}_1 will yield \bar{R}_2 .

In the case $\bar{r}_2 = r_2 > r_1$, as both, (v_1, v_2) and (v_1, \bar{v}_2) are canonical representatives of the lattices they generate, necessarily $\|v\| > r_1$ for all $v \in \bar{R}_i$, $v \neq \pm v_1$, $i = 1, 2$. Thus, if \bar{R}_1 is obtained from a rotation of \bar{R}_2 , then necessarily both lattices are equal, i.e., either $\beta = \theta$ or $r_2 = \frac{r_1}{2 \cos \theta}$ and $\beta = \pi - \theta$. Then, by the identification II' , \hat{F}^+ is well-defined.

If $\bar{r}_2 = r_1$ and $\beta \notin \{\frac{\pi}{3}, \frac{2\pi}{3}\}$, again $\|v\| > r_1$ for all $v \in \bar{R}_2$, $v \neq \{\pm v_1, \pm \bar{v}_2\}$ (recall the proof of Proposition 2.2). Thus, if \bar{R}_1 is obtained from a rotation of \bar{R}_2 , then either both lattices are equal or $\beta = \pi - \theta$. By using Γ , \hat{F}^+ is again well-defined.

Finally, if $\bar{r}_2 = r_1$ and $\beta \in \{\frac{\pi}{3}, \frac{2\pi}{3}\}$, then \hat{F}^+ would be well defined by identifications Γ or II' .

Once \hat{F}^+ is proven to exist, Lemma 3.1 yields that it's a homeomorphism. ■

From Lemma 3.4, the proof of Proposition 3.2 will be completed by proving that \hat{Y}^+ is homeomorphic to \mathbb{R}^3 . In fact, we will give a canonical homeomorphism to the following quotient set \hat{U}^+ , which easily turns out homeomorphic to $\mathbb{R}^+ \times \mathbb{R}^2$ (and then to \mathbb{R}^3) and admits the required structure of orbifold (see Figure 8).

LEMMA 3.5. *The space \hat{Y}^+ is canonically homeomorphic to $\hat{U}^+ = \bar{U}^+ / \sim_{I', II'}$ where $\bar{U}^+ = \{(r_1, 0, r_2, \theta) \in \bar{Y}^+ : r_2 \geq r_1\}$ and I', II' are the restrictions of the identifications defined above.*

Proof. The map $\hat{d}^+ : \hat{Y}^+ \rightarrow \hat{U}^+$ defined by:

$$\hat{d}^+([(r_1, 0, r_2, \theta)]) = \begin{cases} (r_1, 0, r_2, \theta) & \text{if } r_2 \geq r_1, \\ (r_2, 0, r_1, \pi - \theta) & \text{if } r_2 < r_1, \end{cases}$$

is a homeomorphism. In fact, it is well-defined by identifications Γ , II' , III' , IV' , continuous by I' , and its inverse can be seen as a natural inclusion. ■

3.2. CASE $H = CO^+(2, \mathbb{R})$. In this case, two lattices are identified if and only if there exists an orientation-preserving conformal transformation between the corresponding flat Riemannian tori or, equivalently, if and only if the associated Riemann surfaces are equal (see [6, Sect. IV.7]). As in the previous case, the constructive procedure of the homeomorphism for the following proposition not only yields the result, but the orbifold structure asserted in Theorem 1.1. Even though the procedure in this case is analogous to the previous case with one identification more, we sketch it for its interest (compare with [6, p. 198, Theorem]).

PROPOSITION 3.6. *If $H = CO^+(2, \mathbb{R})$, then G_H is homeomorphic to \mathbb{R}^2 .*

Put $Y_1^+ = \{(1, 0, r_2, \theta_2) \in Y^+\}$ and denote by \bar{Y}_1^+ its closure in \bar{X} . Consider the map $\bar{\alpha}_1^+ : \bar{X} \rightarrow \bar{Y}_1^+$

$$\bar{\alpha}_1^+(v_1, v_2) = \frac{1}{r_1} \bar{\alpha}^+(v_1, v_2). \tag{7}$$

Again, this map, $\bar{\alpha}_1^+$ can be seen as a quotient projection on the topological space \bar{Y}_1^+ obtained by identifying the points in \bar{X} with the same image.

Reasoning as in the previous case, the relation of equivalence in \bar{Y}_1^+ is defined by the identifications:

I'. For $(1, 0, r_2, \theta) \in \bar{Y}_1^+$:

$$(1, 0, r_2, \theta) \sim \left(1, 0, \frac{1}{r_2}, \pi - \theta\right).$$

II'. For $r_2 = \frac{-1}{2 \cos \theta}$, $\frac{\pi}{2} < \theta \leq \frac{2\pi}{3}$:

$$\left(1, 0, \frac{-1}{2 \cos \theta}, \theta\right) \sim \left(1, 0, \frac{1}{2 \cos \theta}, \pi - \theta\right).$$

Let \hat{Y}_1^+ be the corresponding quotient set \bar{Y}_1^+ . Reasoning as in Lemma 3.3, the map $\hat{\alpha}_1^+ : \hat{X} \rightarrow \hat{Y}_1^+$ is a quotient projection on the topological space \hat{Y}_1^+ and, by similar arguments as in the previous case:

LEMMA 3.7. *The unique map $\hat{F}_1^+ : G_H \rightarrow \hat{Y}_1^+$ which makes commutative the diagram:*

$$\begin{array}{ccc} Gl^+(2, \mathbb{R})/Sl(2, \mathbb{Z}) & \xrightarrow{F} & \hat{X} \\ \searrow \pi & & \swarrow \hat{\alpha}_1^+ \\ G_H & \xrightarrow{\hat{F}_1^+} & \hat{Y}_1^+ \end{array}$$

is a homeomorphism.

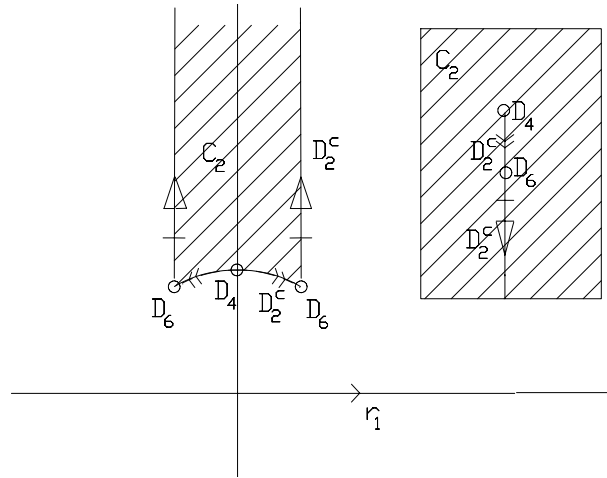

Figure 8: The points in $\hat{U}^+ \equiv \hat{Y}^+ \equiv G_H$, $H = O^+(2, \mathbb{R})$ for fixed r_1 (if $r_1=1$ the set is $\hat{U}_1^+ \equiv \hat{Y}_1^+ \equiv G_H$, $H = CO^+(2, \mathbb{R})$). The curves with arrows of the same type in the left picture are identified yielding topologically the right picture.

Let $U_1^+ = \{(1, 0, r_2, \theta) \in \bar{Y}_1^+ : r_2 \geq 1\}$ and let \hat{U}_1^+ be its quotient by identifications I', II'. Now, one has (Figure 8):

LEMMA 3.8. *The space \hat{Y}_1^+ is canonically homeomorphic to \hat{U}_1^+ .*

3.3. CASES $H = O(2, \mathbb{R})$, $H = CO(2, \mathbb{R})$. In the present subsection, we study what happens if the restriction on orientation-preserving for the identifications, is removed in the two previous cases. Essentially, the new non-orientation preserving identifications make a topological distinction between the classes corresponding to the “generic” oblique crystal system, which become a topological manifold, and the classes of the other four crystal systems, which will lie in the boundary of such manifold. But, from the viewpoint of differentiability, a further distinction appears naturally: the classes corresponding to the rectangular (centered or not) system are distributed in smooth connected parts of the boundary, and the classes of the square and hexagonal systems belong to the edge of the boundary.

For the case $H = O(2, \mathbb{R})$ our aim is to prove:

PROPOSITION 3.9. *If $H = O(2, \mathbb{R})$, then G_H is homeomorphic to \bar{U} , defined as the closure in \bar{Y}^+ of:*

$$U = \left\{ (r_1, 0, r_2, \theta) \in Y^+ : r_2 \geq r_1, \theta \leq \frac{\pi}{2} \right\}$$

The concrete homeomorphism in the proof becomes natural for all the identifications and, as \bar{U} is a subset of \mathbb{R}^3 , its required topological and differentiable structure becomes obvious.

Let $Y = \{(r_1, 0, r_2, \theta) \in Y^+ : \theta \leq \frac{\pi}{2}\}$ and \bar{Y} its closure in \bar{Y}^+ . Consider the map $\bar{\alpha} : \bar{X} \rightarrow \bar{Y}$

$$\bar{\alpha}(v_1, v_2) = L \circ \bar{\alpha}^+(v_1, v_2), \tag{8}$$

where $L : \bar{Y}^+ \rightarrow \bar{Y}$ is defined by:

$$L(r_1, 0, r_2, \theta) = \begin{cases} (r_1, 0, r_2, \theta) & \text{if } \theta \leq \frac{\pi}{2}, \\ (r_1, 0, r_2, \pi - \theta) & \text{if } \theta > \frac{\pi}{2}. \end{cases}$$

Again $\bar{\alpha}$ can be seen as a quotient projection on the topological space \bar{Y} . By applying the arguments in previous cases, consider the relation of equivalence in \bar{Y} induced by the following identification:

I'. For $(r_1, 0, r_2, \theta) \in \bar{Y}$:

$$(r_1, 0, r_2, \theta) \sim (r_2, 0, r_1, \theta).$$

(The identifications corresponding to II', III' and IV' would not add new conditions). Let \hat{Y} be the quotient set of \bar{Y} under identification I'. Reasoning as in Lemma 3.3, the map $\hat{\alpha} : \hat{X} \rightarrow \hat{Y}$ is a quotient projection on the topological space \hat{Y} and as in Lemma 3.4:

LEMMA 3.10. *The unique map $\hat{F} : G_H \rightarrow \hat{Y}$ which makes commutative the following diagram is a homeomorphism:*

$$\begin{array}{ccc} Gl^+(2, \mathbb{R})/Sl(2, \mathbb{Z}) & \xrightarrow{F} & \hat{X} \\ \searrow \pi & & \swarrow \hat{\alpha} \\ G_H & \xrightarrow{\hat{F}} & \hat{Y} \end{array}$$

Thus, the result follows applying the arguments of Lemma 3.5 to $L \circ \hat{d}^+ : \hat{Y} \rightarrow \bar{U}$ in order to obtain:

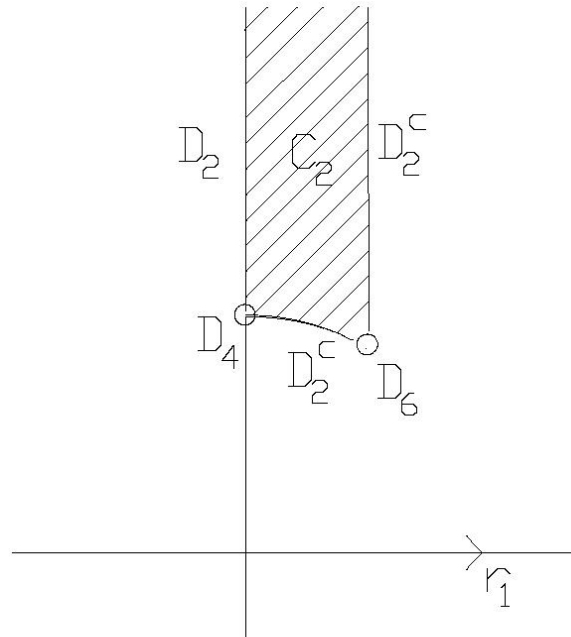

Figure 9: The points in $\bar{U} \equiv G_H$, $H = O(2, \mathbb{R})$ for fixed r_1 (if $r_1 = 1$ the set is $\bar{U}_1 \equiv G_H$, $H = CO(2, \mathbb{R})$).

LEMMA 3.11. *The space \hat{Y} is homeomorphic to \bar{U} .*

Finally, following analogous steps to previous cases, it is easy to check that the result for $H = CO(2, \mathbb{R})$ relies on the proof of:

PROPOSITION 3.12. *If $H = CO(2, \mathbb{R})$, then G_H is homeomorphic to \bar{U}_1 , defined as the closure in \bar{Y}^+ of*

$$U_1 = \left\{ (1, 0, r_2, \theta) \in Y^+ : r_2 \geq 1, \theta \leq \frac{\pi}{2} \right\}.$$

ACKNOWLEDGEMENTS

The author acknowledges deeply the encouragement and support by Professor Miguel Sánchez from the University of Granada, as well as by the MCyT-FEDER research project MTM2007-60731.

REFERENCES

- [1] G. BURNS, A. M. GLAZER, “Space Groups for Solid State Scientists”, Academic Press, Inc., Boston, MA, 1990.
- [2] M. BERGER, P. GAUDUCHON, E. MAZET, Le spectre d’une variété riemannienne, Lecture Notes in Mathematics, 194, Springer-Verlag, Berlin-New York, 1971.
- [3] W. CHEN, A Homotopy Theory of Orbispaces, arXiv:math/0102020v3.
- [4] W. CHEN, Y. RUAN, A new cohomology theory of orbifold *Commun. Math. Phys.* **248** (1) (2004), 1–31.
- [5] S. CHOI, Geometric structures on orbifolds and holonomy representations, *Geom. Dedicata* **104** (2004), 161–199.
- [6] H. FARKAS, I. KRA, “Riemann Surfaces”, Second Ed., Graduate Texts in Mathematics, 71, Springer-Verlag, New York-Berlin, 1992.
- [7] B. IVERSEN, “Hyperbolic Geometry”, London Mathematical Society Student Texts, 25, Cambridge University Press, Cambridge, 1992.
- [8] Y. M. KOH, Note on the conformal classes of tori with L^p -bounded second fundamental form, *Commun. Korean Math. Soc.* **11**,(1) (1996), 201–207.
- [9] F. J. PALOMO, A. ROMERO, Conformally stationary Lorentzian tori with no conjugate points are flat, *Proc. Amer. Math. Soc.* **137** (7) (2009), 2403–2406.
- [10] A. ROMERO, M. SÁNCHEZ, New properties and examples of incomplete Lorentzian tori, *J. Math. Phys.* **35** (4) (1994), 1992–1997.
- [11] M. SÁNCHEZ, Structure of Lorentzian tori with a Killing vector field, *Trans. Am. Math. Soc.* **349** (3) (1997), 1063–1080.
- [12] I. SATAKE, On a generalization of the notion of manifold, *Proc. Nat. Acad. Sci. U.S.A.* **42** (1956), 359–363.
- [13] W. P. THURSTON, “Three-Dimensional Geometry and Topology, Vol. 1”, (Silvio Levy, Ed.), Princeton Mathematical Series, 35. Princeton Univ. Press, Princeton, NJ, 1997.
- [14] A. TROMBA, “Teichmüller Theory in Riemannian Geometry”, Lecture notes prepared by Jochen Denzler, Lectures in Mathematics ETH Zürich, Birkhäuser Verlag, Basel, 1992.
- [15] F. WITT, Conformal properties of harmonic spinors and lightlike geodesics in signature $(1, 1)$, *J. Geom. Phys.* **46** (1) (2003), 74–97.